

MODEL DC-1A/AE2A

Digital Low Voltage Aqualytic Spark Tester

- >> Reliable D.C. Spark Testing at any speed
- >> Available in 1KV
- >> Built-in Air Wipe dries the product after test
- >> Non-destructive
- >> CE approved

The DC-1A/AE2A DC Spark Tester with Aqualytic Electrode represents the latest in spark test technology for producers of products too fragile for a high contact electrode. The AE2A Aqualytic Electrode holds a conducting liquid which completely encompasses the insulation surface and acts as an electrode, applying the entire test potential to the moving product. Because there is no mechanical contact with the product, ultra-thin film, foam and miniature cable insulations as well as magnet wire coatings can be tested accurately without damage. Products to 0.125" in diameter may be tested at typical wire line speeds.

Digital test voltage and fault count displays are vivid and easy to read. Wiring and setup are done externally-there is no need to open up the unit. Membrane switches on the display panel allow the operator to configure the spark tester in a variety of modes and to set the length of time that process control relay contacts are energized after a fault occurs. Relay contacts are accessible on a rear panel connector for easy wiring to external alarms, lights or machines that are to be controlled by the spark tester. The standard RS-485 serial interface can receive and respond to digital commands. Spark tester voltage can be set or verified, the fault count and interlock status can be monitored, and many other tasks can be performed by computer or PLC.

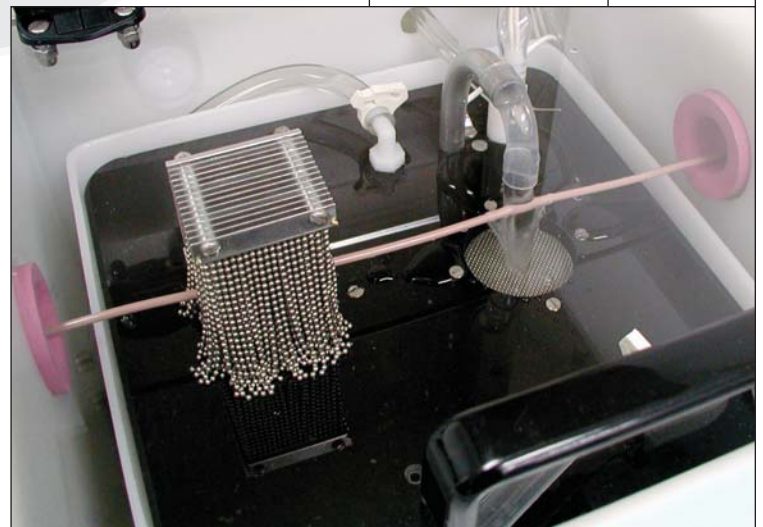

Bead chain shown for water removal. The bead chain may be removed when mechanical contact with the product is prohibited.

Clinton
INSTRUMENT COMPANY

DC-1A/AE2A SPECIFICATIONS

Voltage Test Range	
Model DC-1A	50v to 1KV (minimum voltage varies on electrode design.)
Current Consumption	1 ampere maximum.
Voltage Display	Red 3-digit 14.2mm high LED display.
Voltage Accuracy	+/-2% of reading.
Fault Indication	red 3-digit 14.2mm high LED display; amber indicating light.
Fault Response	Less than 1 millisecond.
Fault Threshold Current	200uA @ 1000v.
Output Current:	
Model DC-1A	2 milliamperes maximum.
Detection Sensitivity	
Model DC-1A	200 μ a. at 1000v.
Operating Modes	Continuous HV/Remove HV on Fault. Momentary Process Control/Latch until Reset.
Process Control	Relay, form "C" contacts rated 1 amp max @ 240VAC, 2 amps max @ 120VAC, for both NO and NC circuits.

Communications	RS-485 Serial Interface; Analog (optional); Ethernet (optional); Profibus (optional).
Dimensions	60.83 - 63.75" [1545.0 - 1619.2] H x 19.00" [482.6] W x 23.00" [584.2] D.
Weight	200 lbs.
Power Requirements	100 to 240V AC 49-61 Hz. Power supply is self-adjusting.
Safety	Designed to IEC-1010.

CONTROL UNIT

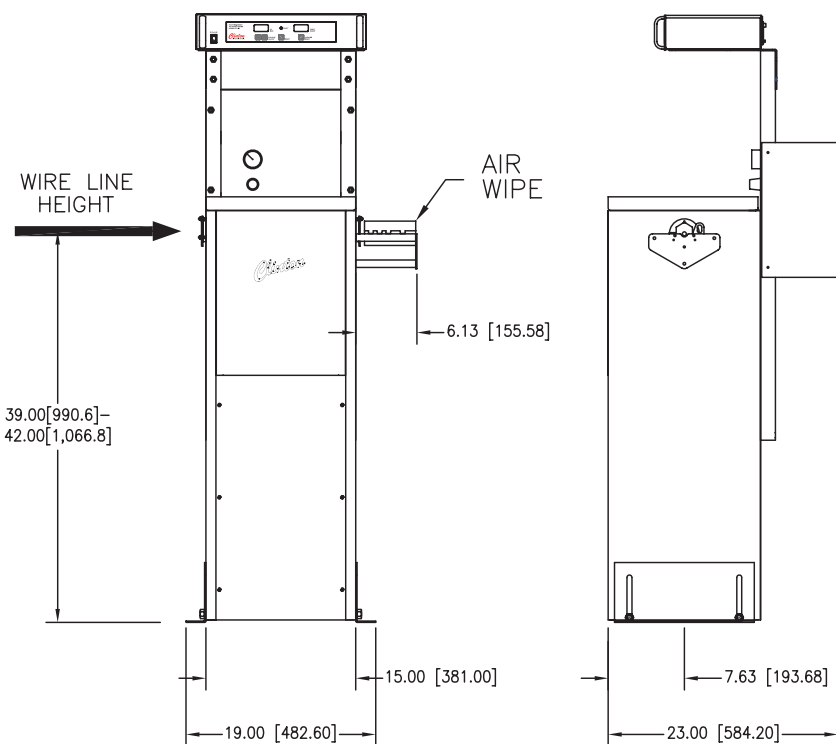

BOTTOM VIEW
SHOWING MOUNTING LOCATIONS

